

Description

Type	Safety and Relief valve
Connections	Threaded BSP / NPT
Rating	PN-40
Material	Stainless steel 316 L
Temperature range	-10 to +350°C
Cryogenic service until	-196°C

Requirements

Calculation	EN-4126-1 / 7
Design	EN-12516-1, EN-4126-1 / 7
	DIN 259 and ANSI B2.1
Materials	EN
Inspection	EN-4126-1 / 7

Construction and materials

Item	Description	Material	
		Standard	Cryogenic
1	Nozzle	316 L SS	316 L SS
2	Body	SA 351 CF-3M	SA 351 CF-3M
4	Cap	SA 351 CF 8	SA 351 CF 8
5	Disc	316 L SS	316 L SS
6	Guide	316 L SS	316 L SS
7	Push Road	316 L SS	316 L SS
8	Spring Button	303 SS	303 SS
9	Ajusting Screw	303 SS	303 SS
10	Tensor Nut	303 SS	303 SS
11	Spring	303 SS	17 / 7PH
12	Lever	SA 351 CF 8	SA 351 CF 8
17	Release nut	306 L SS	306 L SS
18	Lever axis	303 SS	303 SS
19	Packing lever axis	303 SS	303 SS
20	Gasket	PTFE	PCTFE
21	Gasket	PTFE	PCTFE
22	Gasket	Viton	PCTFE
28	O' ring disc	Viton / PTFE	Metal

○ Recommended spare parts

Palanca manual
Lifting device

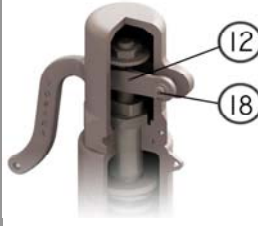

Palanca estanca
Sealed packing lever

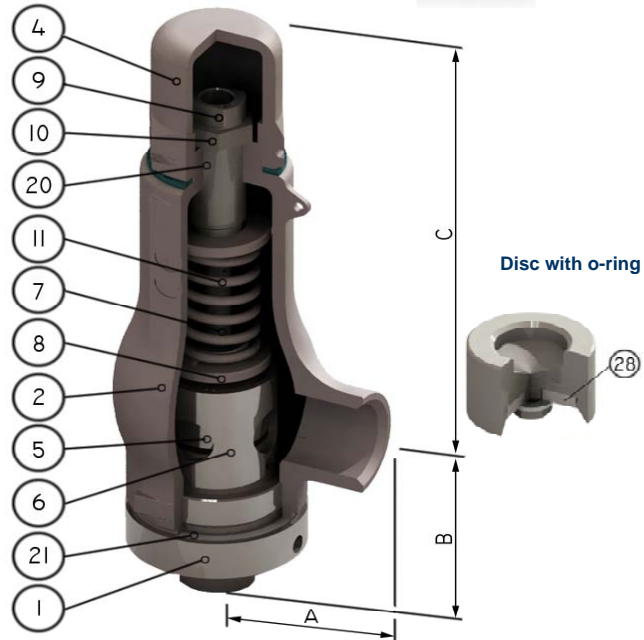

Technical information

Applications	Steam, gases, vapours and liquids
Min. Set pressure	0,2 barg
Overpressure	10%
Blowdown	Gases 10%, liquids 20%
Tolerance Set pressure	± 3%
Discharge coefficients	k= 0,55 for gases k= 0,48 for liquids

Dimensions

Inlet	Outlet	Orifice	Area (mm ²)	A (mm)	B (mm)	C (mm)	Weight (kg)
1/2"	3/4"	13	133	45	57	155	2,2
1/2"	1"	13	133	45	57	155	2,2
3/4"	1"	14	154	45	57	155	2,2
1"	1"	16	201	45	60	155	2,2
1"	1 1/4"	16	201	45	61	155	2,3
1 1/4"	1 1/4"	18	254	45	62	155	2,4
1 1/2"	2"	28	616	62	89	234	4,6
2"	2"	32	804	62	93	234	5,1



94/9/EC ATEX