

9300

1"-DN400 PN10-16-25

HELYON

5 Chemin du Jubin 69570 DARDILLY
Tél. +33 (0)4 72 52 16 70 - Fax +33 (0)4 72 52 16 71
www.helyon.com / E-mail : contact@helyon.com

Bifunctional Air Vacuum Valve

CONSTRUCTION MATERIALS / COATING

Body and Cover: Ductile Iron EN GJS-500-7

Float ball and Internal Mechanisms Stainless Steel A304 (optional A316)

Seat: stainless steel A304 + NBR.EPDM of high durability

Bolting: Internal stainless steel A2 / External in galvanized steel

Coating: Non-toxic Epoxy for drinkable water. Internal and external 200 microns thickness

Other material and special coating available upon request

TECHNICAL DATA / ENGINEERING

AERATION CAPABILITIES

BIG ORIFICE (FILLING / EMPTYING)

Consult us.

TEST PRESSURE	BODY	SEAT
PN 10	15 bar	11 bar
PN 16	24 bar	18 bar
PN 25	38 bar	28 bar

GENERAL DIMENSIONS AND WEIGHTS

DN	Connections	ØA	B	Weight
1"	F Thread	98	215	4
1"	Flange	115	235	4
2"	F Thread	138	245	9
DN50	Flange	138	245	10
DN60/65	Flange	138	250	11
DN80	Flange	170	350	20
DN100	Flange	210	379	31
DN150	Flange	386	540	79
DN200	Flange	483	650	151
DN250	Flange	597	845	214
DN300	Flange	699	1010	345
DN350	Flange	778	1.105	460
DN400	Flange	851	1.210	592

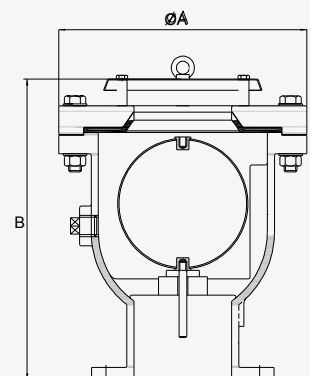

Dimensions in mm and weights in kgs Connections: PN10-16-25 s/EN -150# s/ANSI

ORDERING OPTIONS

- Pipe away version
- Lateral drain valve
- Special closure for lower working pressure than 1 bar

FULFILLED STANDARDS

- EN 1074-1 & EN 1074-4
- AWWA C512



DESCRIPTION

The automatic bi-functional valve of clean water and full bore valves with only one body being the entry and the exit equal to the DN specifications. The valve should perform the following functions:

1. Exhausts large amounts of air during the filling process to ensure that the air can reach the outlet at the velocity of sound without the float ball being elevated and the mechanism shutting prematurely.
2. Admits large quantities of air during line breaks and draining operations to avoid vacuum in the pipe.

Closes watertight apart from 1 bar

Consult for lower working pressures

Fluid

Clean water, consult operations y materials for lower working pressure

KINETIC DESIGN. SEQUENCE OF FUNCTIONS

The kinetic air/vacuum valves are specially designed so that the flow of air in evacuations reaches high speeds without the float ball ascending by the effect of this flow, thus allowing a complete air evacuation.

1. During expulsion, the air flow circling around the float ball causes a result of force which keeps the ball in an open position.
2. The flotation of the ball will block the air flow when the water lifts up the ball.



Evacuation of large quantities of air during the filling



The valve is permanently closed until there is a detection of depression.

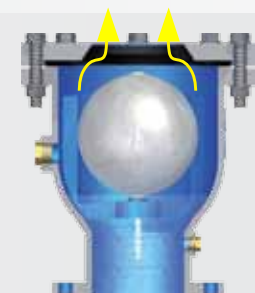

Admission of large quantities of air during the emptying